

Clamping the plastic housing in a vice and attempting to loosen the filter fastening ring with a large pair of metal-jawed grips is highly likely to result in damage.

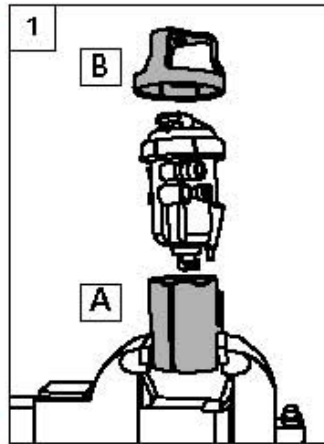

1 Clamp part 'A' into a vice. Remove fuel filter housing from vehicle, taking care to remove all pipes and all electrical connectors. Place the filter housing into part 'A' and locate part 'B' onto the top of the housing, aligning the six slots of the tool with the filter housing fastening ring.

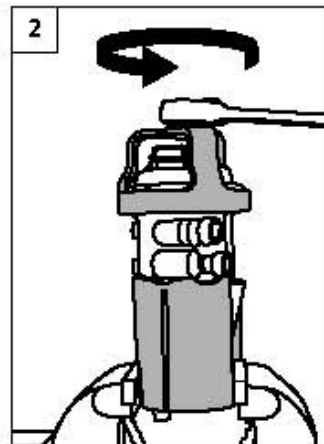

2 Using a 1/2" drive ratchet simply undo the fastening ring by turning part 'B' anti-clockwise.

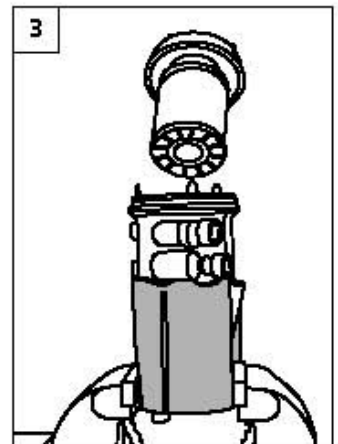

3 Extract the upper section of the filter housing and replace the fuel filter element taking care not to touch the filter paper on the new element.

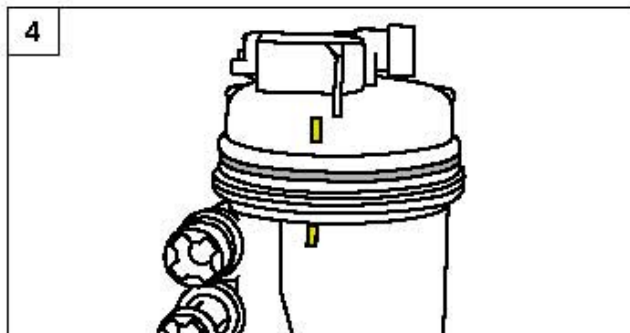

4 Replace the rubber seal between the two sections of the housing with the one supplied with the new filter. Refit the upper section to the housing by aligning the yellow/green markers.

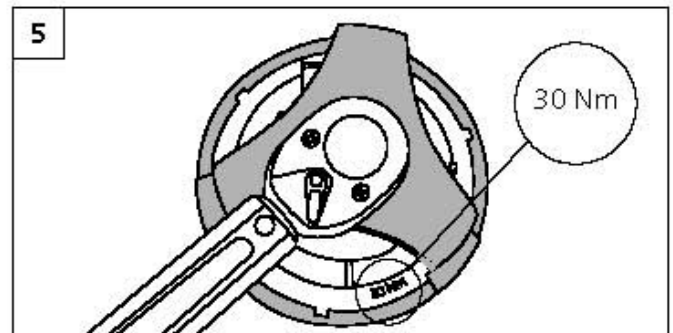

5 Tighten the fastening ring to 30Nm, then refit the housing to the vehicle and reconnect all fuel pipes and electrical connectors. Start the engine and check for leaks.

Note: The fuel filter is 'self bleeding'.

Applications include:

- Chevrolet Captiva 2.0 VCDi 2007>
- Chevrolet Epica 2.0 VCDi 2008>
- Citroen Relay 2.0, 2.2, 2.8, 3.0 HDi 2002>
- Fiat 500 1.3 JTD 2007>
- Fiat Doblo 1.3 JTD 2004>2010
- Fiat Ducato 2.0, 2.2, 2.3, 2.8, 3.0 JTD 2002>
- Fiat Idea 1.3, 1.9 JTD 2004>
- Fiat Multipla 1.9 JTD 2002>2010
- Fiat Panda 1.3 JTD 2004>
- Fiat Punto 1.3, 1.9 JTD 2001>2010
- Fiat Sedici 1.9, 2.0 JTD 2006>
- Peugeot Boxer 2.0, 2.2, 2.8, 3.0 HDi 2002>
- Saab 9-3 1.9 TiD 2004>2006
- Suzuki Splash 1.3 DDiS 2008>
- Suzuki Swift 1.3 DDiS 2005>
- Suzuki SX4 1.3 DDiS 2006>
- Vauxhall Agila 1.3 CDTi 2008>
- Vauxhall Astra 1.3, 1.9 CDTi 2004>2010
- Vauxhall Corsa 1.3 CDTi 2003>2006
- Vauxhall Combo 1.3 CDTi 2004>
- Vauxhall Meriva 1.3 CDTi 2005>2010
- Vauxhall Signum 1.9 CDTi 2004>2008
- Vauxhall Tigra 1.3 CDTi 2004>2009
- Vauxhall Vectra 1.9 CDTi 2004>2008
- Vauxhall Zafira 1.9 CDTi 2005>